

Version: 2HAN		Revised: 09-04-2024		Worm Gear Right 90° Angle Gearbox						MRS75-56C				
Customer is responsible in determining that MEP product will fit/perform suitably in the intended application														
A	B	C	E	H	M	P	B1	B2	D1	D2	H1	L1	L2	
86	112	172	12	205	∅ 95 +0.054	∅ 166.1	6.35	4.76	∅ 31.75	∅ 15.875	86	140	80	
L3	L4	T1	T2	AB	BB	CC	KA	KC						
∅ 115	∅ 149.22	34.67	18.11	126	120	75	8-M8-DEEP14	4-∅ 11						

BACK VIEW	
H	Height of gearbox casing.
M	Outer diameter of output hollow shaft sleeve lip.
W	Width of gearbox casing
S	Hole slot size in input flange for motor mounting.
BB	Width of gearbox casing + lip of hollow shaft sleeve seat.
SIDE VIEW	
LA	Horizontal distance from the center of hollow output shaft to the side of the gearbox casing.
LAB	Horizontal distance from the center of hollow output shaft to the outside of the front motor mounting input flange.
E	Input mounting flange thickness.
P	Outer diameter of input motor mounting flange.
L1	Center distance between feet mounting holes.
C	Width of gearbox casing.
KA	Hole size for mounting optional output flange or torque arm.
L3	Bolt circle for mounting optional output flange or torque arm.
F	External width of mounting provisions for optional output flange.
D1	Output shaft diameter.
B1	Width of the output shaft key.
T1	Hollow output shaft diameter + 1/2 key.
FRONT VIEW	
L4	Bolt circle in input motor mounting flange.
CC	Center distance between input & output shafts. (Input & output gears).
H1	Height to the center of the output shaft.
D2	Input shaft diameter.
B2	Width of the input shaft key.
T2	Hollow input shaft diameter + 1/2 key.

# MaxMotion

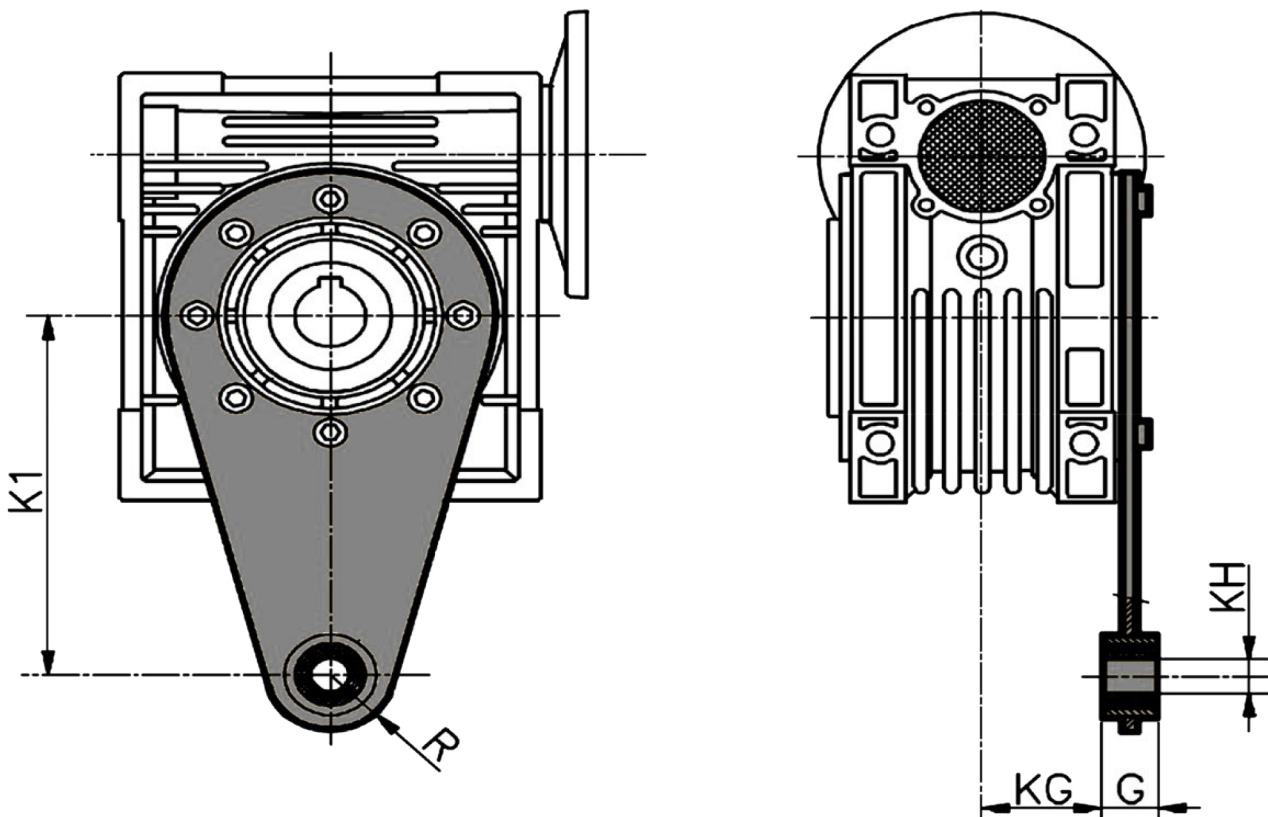

Customer is responsible in determining that MEP product will fit/perform suitably in the intended application

Version: 1HAN

Revised:11-04-2020

SIZE	K1	G	KG	KH	R
75	200	25	46.5	20	30

**MRS75-ARM**

# MaxMotion

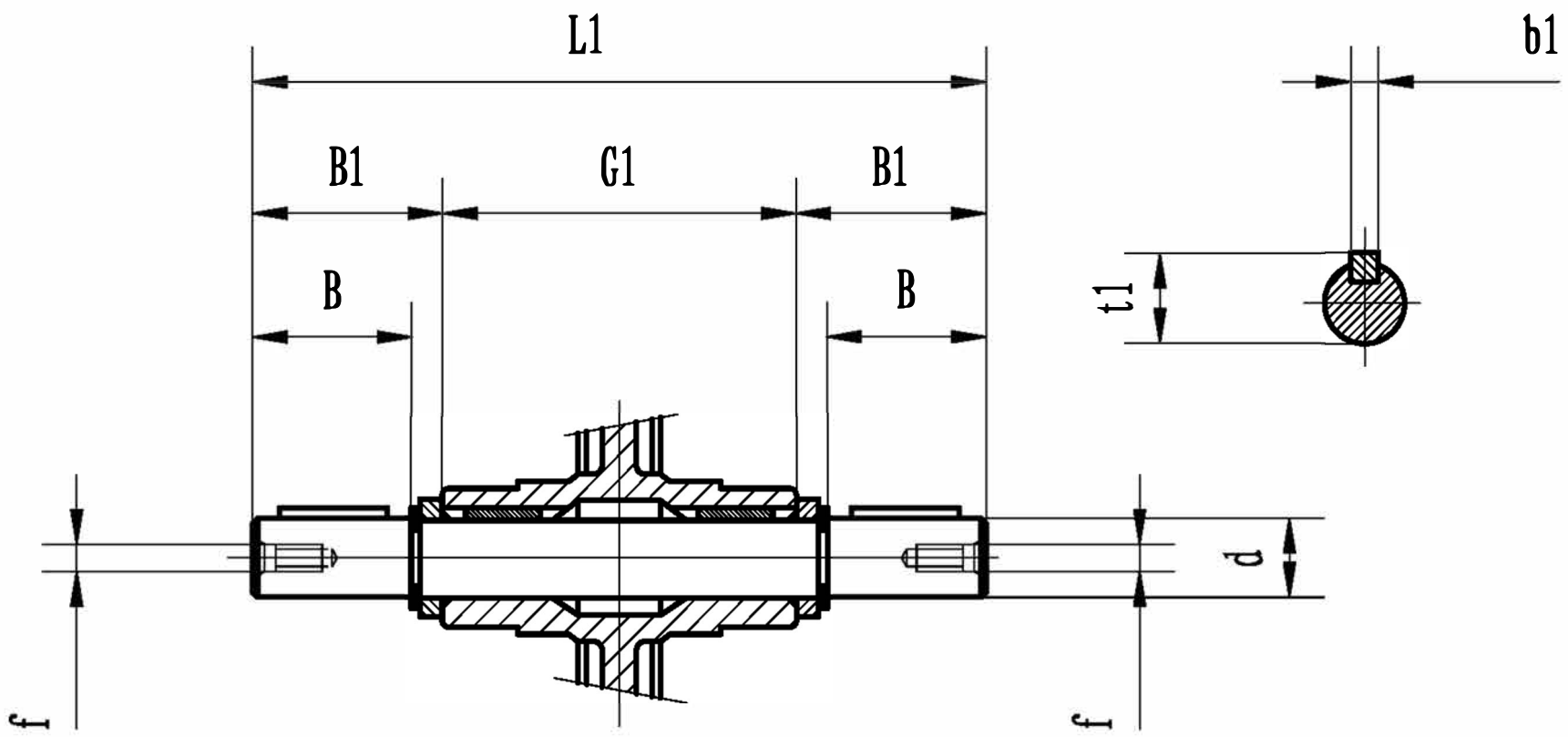

Customer is responsible in determining that MEP product will fit/perform suitably in the intended application

Version: 1HAN

Revised: 04-11-2020

SIZE	B	d	f	L1	B1	b1	G1	t1
75	70	31.75	1/2-13UNC	268.2	70	6.35	124.7	28.15

**MRS75-DOUBLE OUTPUT SHAFT**



# MaxMotion

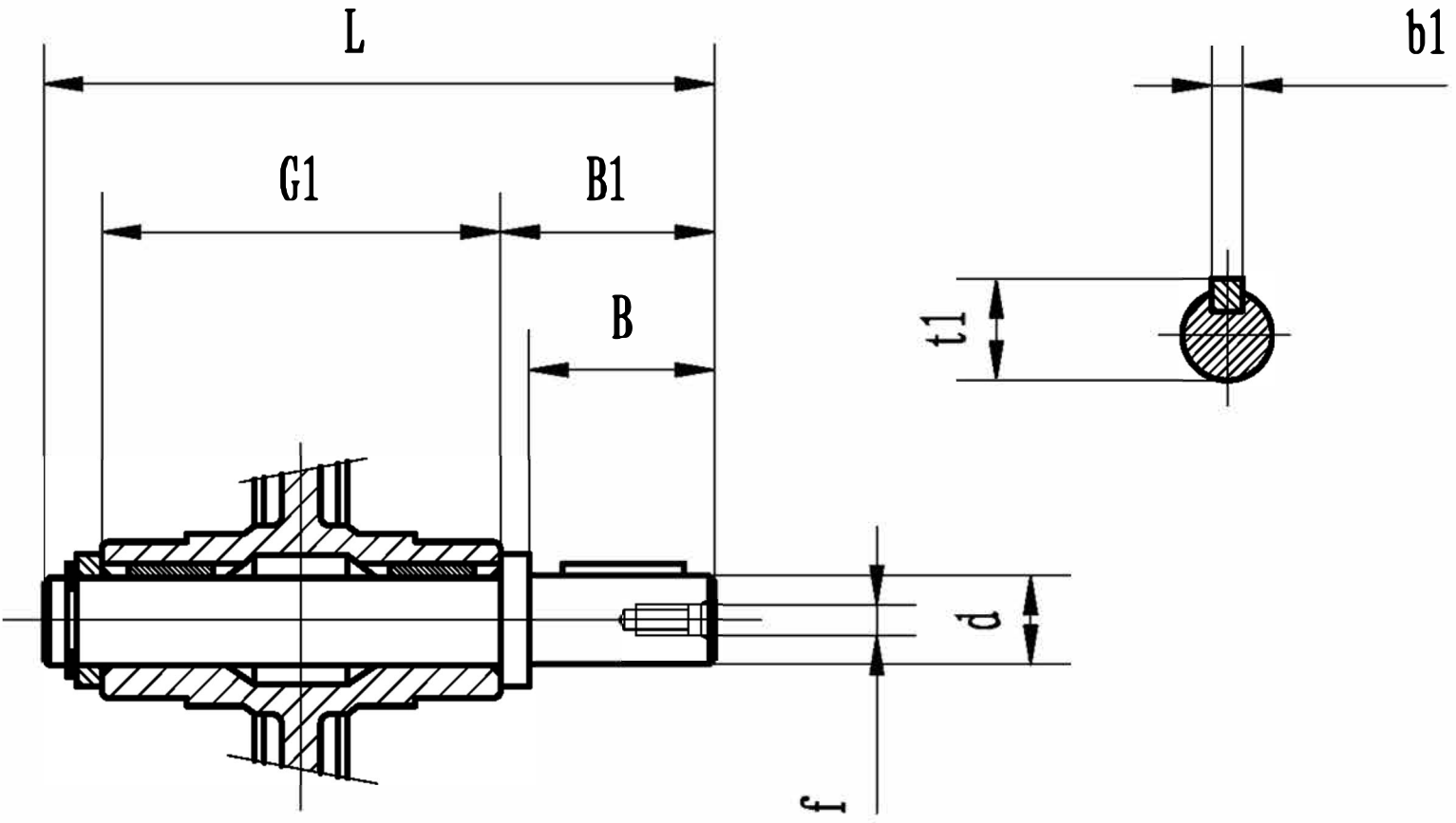

Customer is responsible in determining that MEP product will fit/perform suitably in the intended application

Version: 1HAN

Revised: 30-04-2020

## MRS75-SINGLE OUTPUT SHAFT

SIZE	B	d	f	L	B1	b1	G1	t1
75	70	31.75	1/2-13UNC	202	70	6.35	124.7	28.15

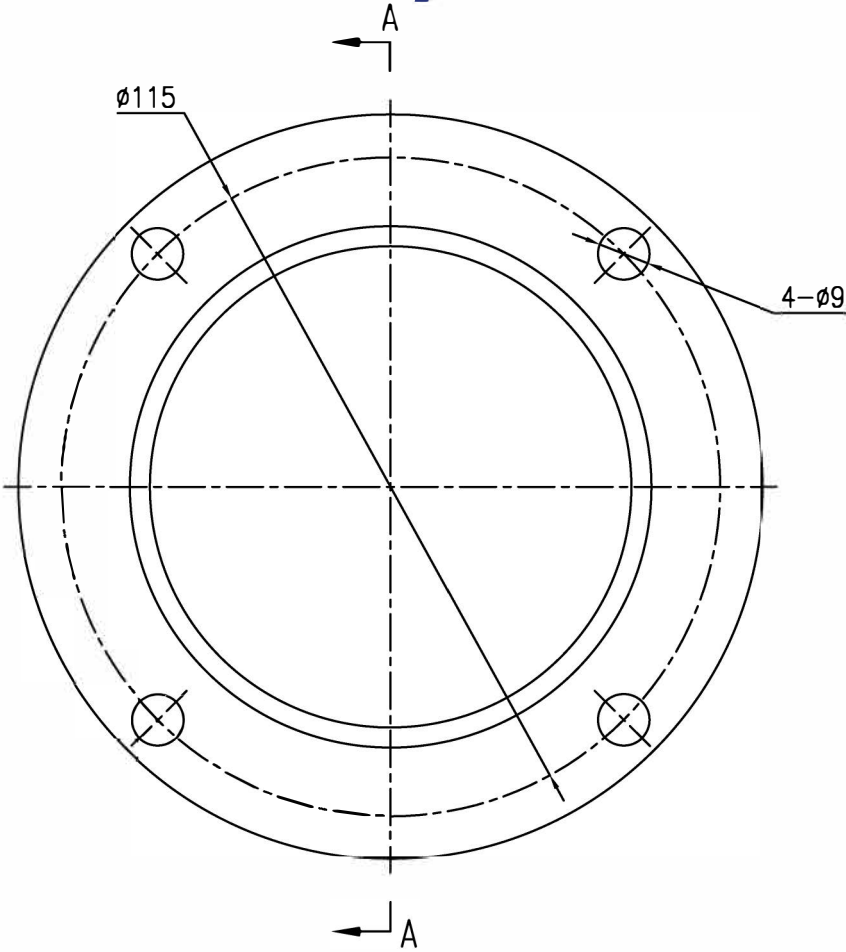
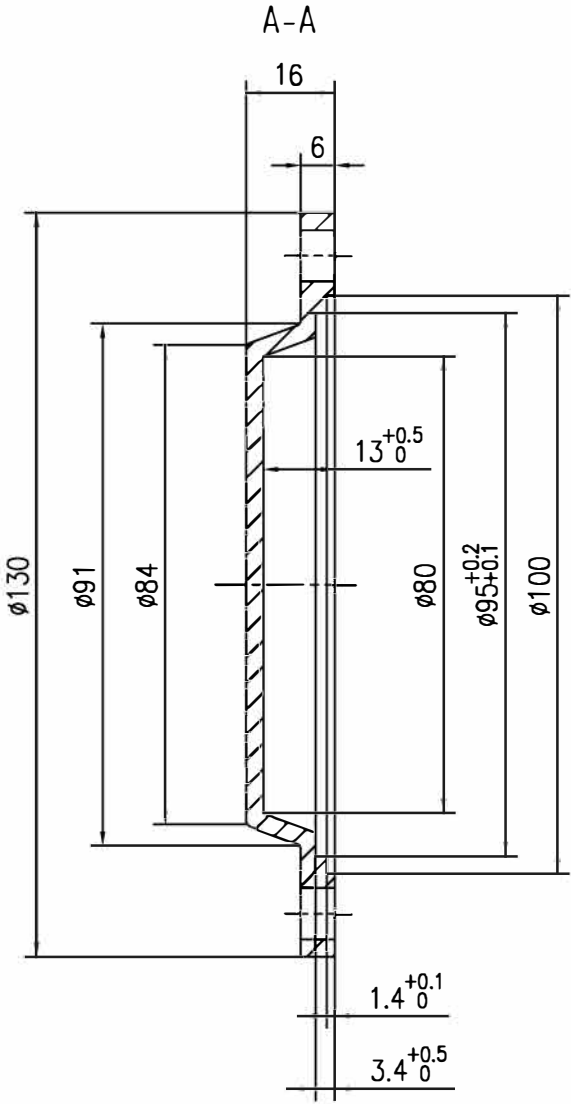

- 1. The cover should incorporate an "O" ring to prevent water.
- 2. The part need to be included six outer hexagon bolt.

**MRS75 COVER**

# RIGHT ANGLE SPEED REDUCER

304 STAINLESS STEEL CONSTRUCTION

MaxMotion



## Features:

- 304 Stainless Steel construction
- Two bearings on Input shaft
- NEMA 56C Face Input
- Double Lip Viton Seals
- O Rings on input and output covers
- Hardened worm shaft
- Permanently sealed with Food Grade Oil
- 140TC come's with 5/8" Stainless Reduction Bushing

## Benefits:

- Resists wash down & has higher thermal capacity
- Allows true alignment & prevents oil leaks
- Allows use of standard NEMA motors
- Prevents leaks and avoids oil contamination
- Seals better than paper gaskets
- Increase durability over forged design
- Plug-in solid shafts for greater mounting flexibility
- Maintenance free, no breather or fill plugs

## MOUNTING VERSIONS

### Standard Hollow Shaft Reducer

- Machined mounting faces on both output sides with tapped mounting holes.

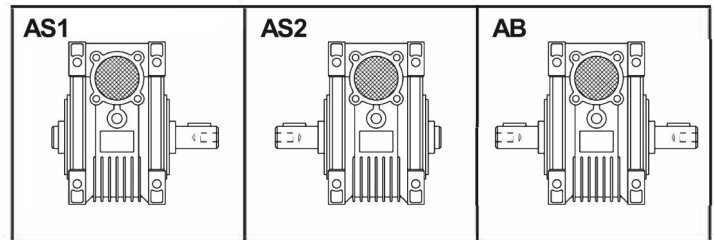

### Solid Single & Double Output Shafts

- Plug into standard hollow shaft.
- Easy field installation.

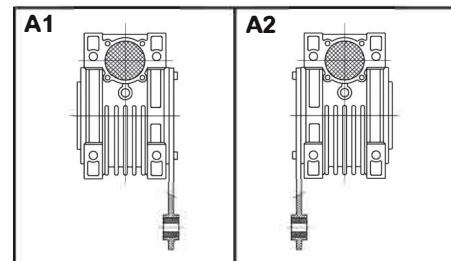

### Bolt-On Torque Arm

- Bolts on to reducer machined face.
- C/W With flexible rubber bushing.

# RIGHT ANGLE SPEED REDUCER

304 STAINLESS STEEL CONSTRUCTION



MODEL	RATIO	OUTPUT RPM	OUTPUT TORQUE	MAX INPUT @ 1750RPM	MAX OHL Lbs	BORE SIZE	SINGLE O.P SHAFT	DOUBLE O.P SHAFT	TORQUE ARM	SANITATION COVER
MRS50-5-56C	5	350	549	3.43	322	1.000"	MRS50-SS-SS	MRS50-DS-SS	MRS50-ARM	MRS50-COVER
MRS50-7.5-56C	7.5	23	638	2.64	369	1.000"	MRS50-SS-SS	MRS50-DS-SS	MRS50-ARM	MRS50-COVER
MRS50-10-56C	10	175	637	2.06	406	1.000"	MRS50-SS-SS	MRS50-DS-SS	MRS50-ARM	MRS50-COVER
MRS50-15-56C	15	117	655	1.48	464	1.000"	MRS50-SS-SS	MRS50-DS-SS	MRS50-ARM	MRS50-COVER
MRS50-20-56C	20	88	646	1.14	510	1.000"	MRS50-SS-SS	MRS50-DS-SS	MRS50-ARM	MRS50-COVER
MRS50-25-56C	25	70	619	.90	551	1.000"	MRS50-SS-SS	MRS50-DS-SS	MRS50-ARM	MRS50-COVER
MRS50-30-56C	30	58	743	.96	586	1.000"	MRS50-SS-SS	MRS50-DS-SS	MRS50-ARM	MRS50-COVER
MRS50-40-56C	40	44	672	.70	643	1.000"	MRS50-SS-SS	MRS50-DS-SS	MRS50-ARM	MRS50-COVER
MRS50M-40-56C	40	44	672	.70	643	25MM	N/A	MRS50-DS-SS	MRS50-ARM	MRS50-COVER
MRS50-50-56C	50	35	646	.57	694	1.000"	MRS50-SS-SS	MRS50-DS-SS	MRS50-ARM	MRS50-COVER
MRS50-60-56C	60	29	602	.47	739	1.000"	MRS50-SS-SS	MRS50-DS-SS	MRS50-ARM	MRS50-COVER
MRS50M-60-56C	60	29	602	.47	739	25MM	N/A	MRS50-DS-SS	MRS50-ARM	MRS50-COVER
MRS50-80-56C	80	22	575	.38	810	1.000"	MRS50-SS-SS	MRS50-DS-SS	MRS50-ARM	MRS50-COVER
MRS50-100-56C	100	18	487	.28	866	1.000"	MRS50-SS-SS	MRS50-DS-SS	MRS50-ARM	MRS50-COVER
MRS63-7.5-56C	7.5	233	1133	4.77	463	1.000"	MRS63-SS-SS	MRS63-DS-SS	MRS63-ARM	MRS63-COVER
MRS63-10-56C	10	175	1150	3.67	510	1.000"	MRS63-SS-SS	MRS63-DS-SS	MRS63-ARM	MRS63-COVER
MRS63-15-56C	15	117	1239	2.76	583	1.000"	MRS63-SS-SS	MRS63-DS-SS	MRS63-ARM	MRS63-COVER
MRS63-20-56C	20	88	1194	2.05	641	1.000"	MRS63-SS-SS	MRS63-DS-SS	MRS63-ARM	MRS63-COVER
MRS63-25-56C	25	70	1150	1.64	692	1.000"	MRS63-SS-SS	MRS63-DS-SS	MRS63-ARM	MRS63-COVER
MRS63-30-56C	30	58	1416	1.77	736	1.000"	MRS63-SS-SS	MRS63-DS-SS	MRS63-ARM	MRS63-COVER
MRS63-40-56C	40	44	1283	1.27	807	1.000"	MRS63-SS-SS	MRS63-DS-SS	MRS63-ARM	MRS63-COVER
MRS63M-40-56C	40	44	1283	1.27	807	25MM	N/A	MRS63-DS-SS	MRS63-ARM	MRS63-COVER
MRS63-50-56C	50	35	1194	1.01	871	1.000"	MRS63-SS-SS	MRS63-DS-SS	MRS63-ARM	MRS63-COVER
MRS63-60-56C	60	29	1150	.86	928	1.000"	MRS63-SS-SS	MRS63-DS-SS	MRS63-ARM	MRS63-COVER
MRS63M-60-56C	60	29	1150	.86	928	25MM	N/A	MRS63-DS-SS	MRS63-ARM	MRS63-COVER
MRS63-80-56C	80	22	1079	.66	1017	1.000"	MRS63-SS-SS	MRS63-DS-SS	MRS63-ARM	MRS63-COVER
MRS63-100-56C	100	15	1044	.57	1088	1.000"	MRS63-SS-SS	MRS63-DS-SS	MRS63-ARM	MRS63-COVER
MRS75-7.5-180TC	7.5	233	1555	6.44	581	1.250"	MRS75-SS-SS	MRS75-DS-SS	MRS75-ARM	MRS63-COVER
MRS75-10-180TC	10	175	1656	5.2	639	1.250"	MRS63-SS-SS	MRS75-DS-SS	MRS63-ARM	MRS63-COVER
MRS75-15-180TC	15	117	1900	4.07	732	1.250"	MRS63-SS-SS	MRS75-DS-SS	MRS63-ARM	MRS63-COVER
MRS75-20-140TC	20	88	1953	3.24	806	1.250"	MRS63-SS-SS	MRS75-DS-SS	MRS63-ARM	MRS63-COVER
MRS75-25-140TC	25	70	1784	2.43	868	1.250"	MRS63-SS-SS	MRS75-DS-SS	MRS63-ARM	MRS63-COVER
MRS75-30-140TC	30	58	2027	2.41	922	1.250"	MRS63-SS-SS	MRS75-DS-SS	MRS63-ARM	MRS63-COVER
MRS75-40-56C	40	44	2029	1.9	1015	1.250"	MRS63-SS-SS	MRS75-DS-SS	MRS63-ARM	MRS63-COVER
MRS75-50-56C	50	35	1880	1.47	1093	1.250"	MRS63-SS-SS	MRS75-DS-SS	MRS63-ARM	MRS63-COVER
MRS75-60-56C	60	29	1778	1.22	1162	1.250"	MRS63-SS-SS	MRS75-DS-SS	MRS63-ARM	MRS63-COVER
MRS75-80-56C	80	22	1632	.91	1279	1.250"	MRS63-SS-SS	MRS75-DS-SS	MRS63-ARM	MRS63-COVER
MRS75-100-56C	100	15	1517	.74	1378	1.250"	MRS63-SS-SS	MRS75-DS-SS	MRS63-ARM	MRS63-COVER

## Available Accessories:



Single output shaft



Double output shaft



Torque Arm



Safety Cover